

Medical Cart Computer

Venus-224/244

22",24" Dual Hot Swappable Battery Medical Cart Computer

intel

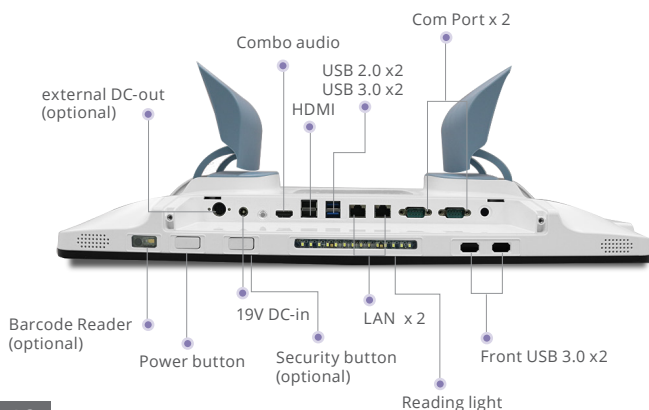
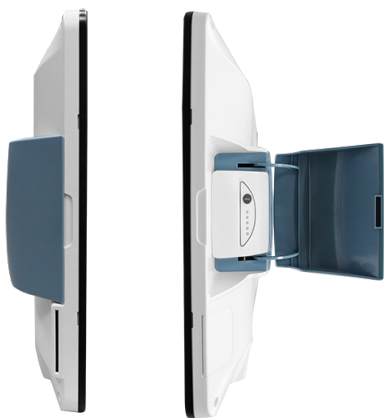

Features

- Intel 11th gen Tigerlake, fan less implementation
- Windows 11 and IGEL Compliant
- Dual Hot Swap Batteries
- Easy cleanable and anti-bacterial by using
- Internal Imprivata compliant RFID reader (optional)
- WiFi 6 (optional)
- Compliant with all Venus batteries
- Remotely Manageable by central IT departments

Specifications

MAIN SPECIFICATIONS

	Venus-224	Venus-244
Processor	Intel® 10nm 11th gen. Tiger Lake i5 Celeron	
System Memory	DDR4 up to 32GB	
OS Support	Microsoft® Windows 11 Microsoft® Windows 10 (64bit) Ubuntu 20.04 LTS IGEL (thin client solution)	
Graphics	Intel® UHD Graphics	
Storage	m.2 SSD up to 512 GB	
Wireless Communication	802.11 ac/a/b/g/n + BT 4.1 (optional) Wifi6 + BT 5.2 (optional)	
Touch	PCT (optional)	
Speaker	3W x2	
Trusted Platform Module	TPM 2.0	
Security	Smart Card Reader (optional) Imprivata RFID reader (optional) Barcode reader (optional)	
Waterproof	Front IP65 ; rear IPX1	

DISPLAY

	Venus-224	Venus-244
Display Size	21.5"	23.8"
Resolution	FHD 1920 x 1080	FHD 1920 x 1080
Max. Colors	16.7M	16.7M
Contrast Ratio	3000:1	3000:1
Luminance (cd/m2)	250	250

I/O

USB	Rear I/O :USB 3.0 x2, USB 2.0 x2 Front button I/O : USB 3.0 x2
Video Out	HDMI 1.4 x1
COM	COM port x2
Audio	Combo audio port x1
Ethernet	1.5kv isolated Gigabit LAN x2
DC-in	19V DC-in x1

MECHANICAL AND ENVIRONMENTAL

VESA	75/100 mm VESA mount	
Operating Temperature	0°C ~ 35°C(32°F ~ 95°F)	
Storage Temperature	-20°C ~ 60°C(-4°F ~ 140°F)	
Storage Humidity	10%~95%@40°C, non-condensing	
Dimension	510(L) x 78.4(W) x 346(H)	560(L) x 78.4(W) x 373(H)
Net Weight	6kg	7kg
Gross Weight	10kg(26.5lbs)	11kg(24.3lbs)
Package Size	645(L) x 210(W) x 513(H) mm	730(L) x 240(W) x 550(H) mm
Certifications	CE: EN 60601-1-2:2015(V4.0), EN 60601-1:2006/ A1:2013(V3.1) FCC: Part 18 Class B UL: ANSI/AAMI ES60601-1:2012 (V3.1) cUL: CAN/CSA-C22.2 No. 60601-1:2014 (V3.1)	

ALL PRODUCT, PRODUCT SPECIFICATIONS AND DATA ARE SUBJECT TO CHANGE WITHOUT NOTICE TO IMPROVE RELIABILITY, FUNCTION OR DESIGN OR OTHERWISE.

22",24" Dual Hot Swappable Battery Medical Cart Computer

Dimension / Unit: mm

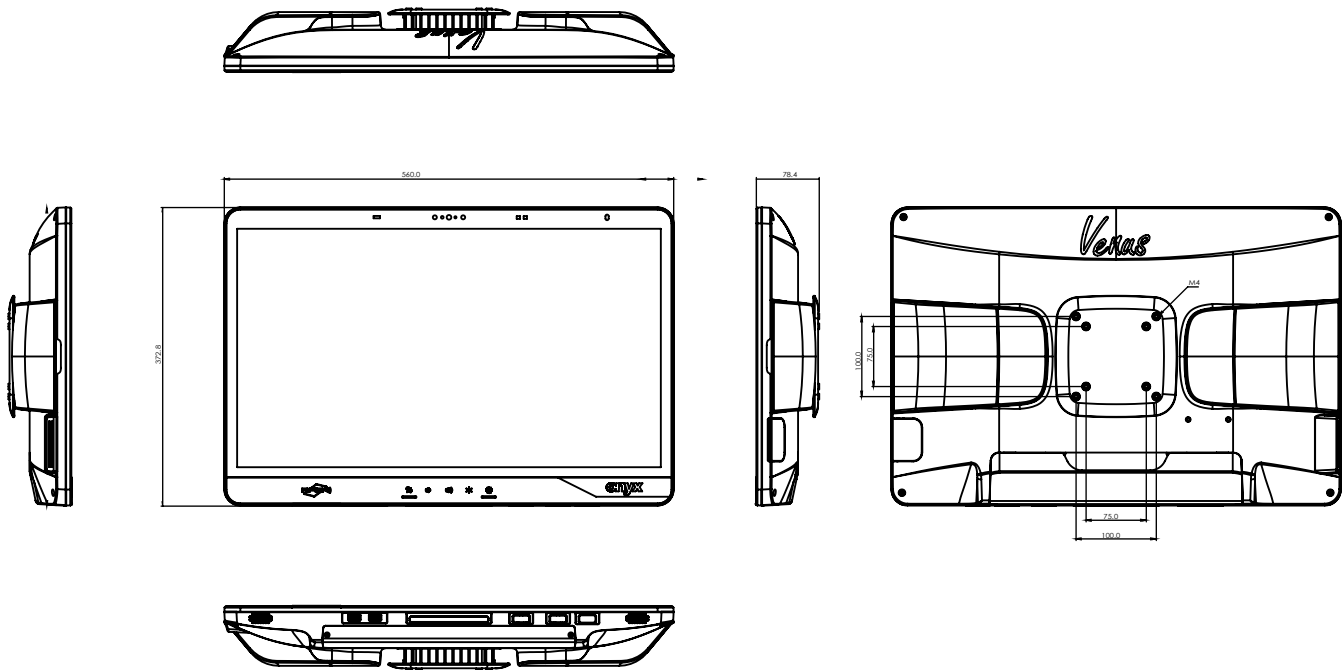

Ordering Information

- VENUS-224-P35-A1-0000
Cart Computer.i5 1135G7.22".Fanless.PCT.TPM
- VENUS-224-G75-A1-0000
Cart Computer.7505.22".Fanless.TPM
- VENUS-244-P35-A1-0000
Cart Computer.i5 1135G7.24".Fanless.PCT.TPM
- VENUS-244-G75-A1-0000
Cart Computer.7505.24".Fanless.TPM

Optional Accessories

- 125530120B
19V medical adapter
- DDR4-08G-04
DDR4 3200 8GB RAM
- SSD-256GB-003
(AOH)(TF)M.2 2242 SSD.TLC.256GB
- OPM-P02T-03
2 XL Battery Kit(long).Li-ion 3S3P.10.95V.Venus/UPower.
volume package(via sea)
- OPM-C12W-A8
WLAN Kit.802.11a/b/g/n/ac w/BT 4.1.dual int. antenna.
Qualcomm Atheros NFA364A.for Venus-22x_M.2
- OPM-C17W-A1
Wifi 6 (intel ax200) for Venus-22x
- OPM-T035-A1
Smart card reader
- OPM-S02R-A3
RFID (imprivata compatible)
- OPM-V02C-A1
Hello camera
- OPM-S09R-A1
Barcode reader
- OPM-T036-A1
Customize physical button
- OPM-T037-A1
Alarm LED